

HITACHI SPLIT AIR CONDITIONERS

Installation and Maintenance Manual

Models

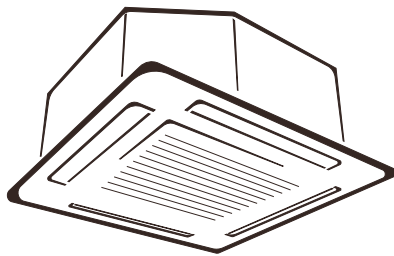

< Indoor Units >

Heat Pump Type
RCI-1.5UNE1NH
RCI-2.0UNE1NH
RCI-3.0UNE1NH
RCI-4.0UNE1NH
RCI-5.0UNE1NH
RCI-6.0UNE1NH
RCI-6.5UNE1NH

Cooling Only Type
RCI-1.5TNE1NH
RCI-2.0TNE1NH
RCI-3.0TNE1NH
RCI-4.0TNE1NH
RCI-5.0TNE1NH
RCI-6.0TNE1NH
RCI-6.5TNE1NH

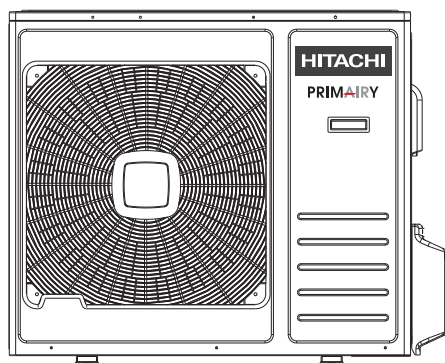

< Outdoor Units >

Heat Pump Type
RAS-1.5UNESNH1
RAS-2.0UNESNH1
RAS-3.0UNESNH1
RAS-4.0UNESNH1
RAS-5.0UMESNH1
RAS-6.0UMESNH1
RAS-6.5UMESNH1

Cooling Only Type
RAS-1.5TNESNH1
RAS-2.0TNESNH1
RAS-3.0TNESNH1
RAS-4.0TNESNH1
RAS-5.0TNESNH1
RAS-6.0TNESNH1
RAS-6.5TNESNH1

IMPORTANT NOTICE

- We pursue a policy of continuing improvement in design and performance of products. The right is therefore reserved to vary specifications without notice.
- We cannot anticipate every possible circumstance that might involve a potential hazard.
- This air conditioner is designed for standard air conditioning only. Do not use this air conditioner for other purposes such as drying clothes, refrigerating foods or for any other cooling or heating process.
- The installer and system specialist shall secure safety against leakage according to local regulations or standards.
- No part of this manual may be reproduced without written permission.
- Signal words (DANGER, WARNING and CAUTION) are used to identify levels of hazard seriousness. Definitions for identifying hazard levels are provided below with their respective signal words.



: Immediate hazards which WILL result in severe personal injury or death.



: Hazards or unsafe practices which COULD result in severe personal injury or death.



: Hazards or unsafe practices which COULD result in minor personal injury or product or property damage.

NOTE

Useful information for operation and/or maintenance.

- It is assumed that this air conditioner will be operated and serviced by English speaking people. If this is not the case, the customer should add safety, caution and operating signs in the native language.
- If you have any questions, contact your distributor or dealer .
- This manual gives a common description and information for this air conditioner which you operate as well as for other models.
- This air conditioner has been designed for the following temperatures. Operate it within this range.

Series	Mode	Outdoor Working Temperature	
		Maximum(°C)	Minimum(°C)
Heat Pump	Cooling Operation	48	-15
	Heatling Operation	24	-15
Cooling Only	Cooling Operation	48	-15

- Storage condition: Temperature -25~60°C
Humidity 30%~80%

This manual should be considered as a permanent part of the air conditioning equipment and should remain with the air conditioning equipment.

CHECKING PRODUCT RECEIVED

- Upon receiving this product, inspect it for any shipping damage. Claims for damage, either apparent or concealed, should be filed immediately with the shipping company.
- Check the model number, electrical characteristics (power supply, voltage and frequency) and accessories to determine if they are correct.

The standard utilization of the unit shall be explained in these instructions.

Therefore, the utilization of the unit other than those indicated in these instructions is not recommended. Please contact your local agent, as the occasion arises.

- We recommend that this air-conditioner be installed properly by qualified installation technicians in accordance with the installation instructions provided with the unit.
- Before installation, check if the voltage of the power supply in your home or office is the same as the voltage shown on the nameplate.

DANGER

- You must not carry on any transformation to this product, otherwise, it may possibly cause such consequences as the water leakage, the breakdown, the short-circuit, an electric shock, fire, etc.
- The work such as tube line welding, etc. should be carried out far away from the flammable explosive material vessels, including the air-conditioner refrigerant, to guarantee the security of the site.
- To protect the air-conditioner from heavy corrosion, avoid installing the outdoor unit where salty seawater can splash directly onto it or in sulphurous air near a spa. Do not install the air-conditioner where excessively high heat-generating objects are placed.







WARNING





- If the supply cord is damaged, it must be replaced by the factory or its service department in case of danger
- The place where this product is installed must have the reliable electrical earth facility and the equipment. Please do not connect the grounding of this product to various kinds of air-feeding tube lines, the drain lines, the lightning protection facility as well as other tube lines to avoid receiving an electric shock and damages caused by other factors.
- Wiring must be done by a qualified electrician. All the wiring must comply with the local electrical codes.
- Consider the capacity of the electric current of your electrical kilowatt-hour meter wires and socket before installation.
- The power wire where this product is installed is supposed to have the independent leakage protective device and the electric current over-load protection device which are provided for this product.
- This appliance is not intended for use by persons (including children) with reduced physical, sensory or mental capabilities, or lack of experience and knowledge, unless they have been given supervision or instruction concerning use of the appliance by a person responsible for their safety. Children should be supervised to ensure that they do not play with the appliance.
- Means for disconnection, which can provide full disconnection in all poles, must be incorporated in the fixed wiring in accordance with the wiring rules.
- When the air conditioner is abnormal, such as burnt smell, appearance deformation, fire, smoke, etc., it is forbidden to continue use air conditioner, the main power switch of air conditioner must be cut off immediately and contact with the agent.

Contents

Safety Precautions	1
Identification of Parts	3
Before Operation	5
Diagram of Refrigerant Cycle & Wiring	8
1.Refrigerant Flow Diagram	8
2.Electrical Wiring Diagram	8
Installation and Maintenance	9
1. Safety Notice	9
2. The Tools and Instruments for Installation.....	10
3. The Installation of the Indoor Unit	10
3.1 The Initial Check.....	11
3.2 Installation(1. 5~2. 0Hp).....	13
3.3 Installation(3.0~6.5Hp).....	15
3.4 Installation Details for Air Panels	17
4. The Installation of the Outdoor Unit.....	18
4.1 The Initial Check	18
4.2 Installation.....	18
4.3 Refrigerant Length between Indoor and Outdoor	19
5. Refrigerant Pipe	20
5.1 The Pipe Material.....	20
5.2 The Connection of the Piping	20
5.3 Air Exhaust.....	21
6. Drain Piping.....	22
7. Electrical Wiring.....	24
7.1 General Check	24
7.2 Electrical Wiring Connection	24
8.Test Run	25
9. Common.....	26

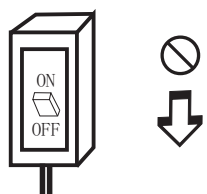
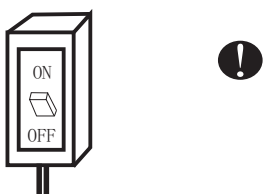
Symbols in this User's Manual are interpreted as shown below:

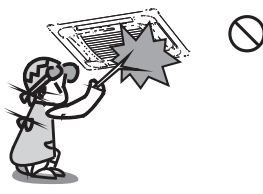
-  Be sure not to do.
-  The feature of the appliance, instead of a fault.
-  Pay attention to such a situation.
-  Be sure to follow the instruction.
-  Grounding is necessary.
-  Warning: Incorrect handling could cause a serious hazard, such as death, serious injury, etc.

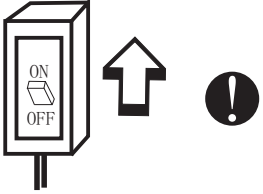
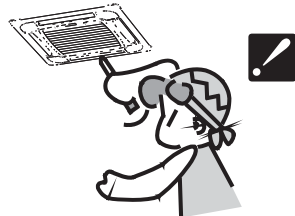
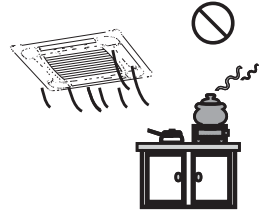
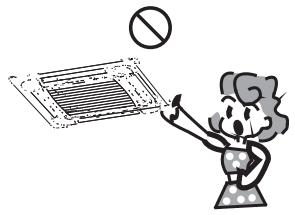
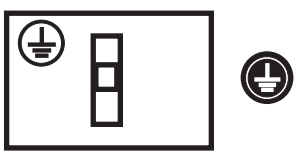
 <p>Do not use the power supply circuit breaker or pull off the plug to turn it off during operation. This may cause a fire due to spark, etc.</p>	 <p>Keep the power supply circuit breaker or plug from dirt. Connect the power supply cord to it firmly and correctly, lest an electric shock or a fire break out due to insufficient contact.</p>	 <p>Used correct power supply in accordance with the rating plate requirement . Otherwise, serious faults may be occur or a fire may be break out.</p>
 <p>Do not knit, pull or press the power supply cord, lest the power supply cord be broken. An electric shock or fire is probably caused by a broken power supply cord.</p>	 <p>Never insert a stick or similar to the unit. Since the fan rotates at high speed, this may cause an injury.</p>	 <p>It is harmful to your health if the cool air reaches you for a long time. It is advisable to let the air flow be deflected to all the room.</p>
 <p>Turn off the appliance first before cutting off power supply when malfunction occurs.</p>	 <p>Do not repair the appliance by yourself. If this is done incorrectly, it may cause an electric shock, etc.</p>	 <p>Prevent the air flow from reaching the gas burners and stove.</p>
 <p>Do not touch the operation buttons when your hands are wet.</p>		 <p>It is the user's responsibility to make the appliance be grounded according to local codes or ordinances by a licenced person.</p>

Operating condition

The protective device maybe trip and stop the appliance in the cases out of the allowable temperature range .

If the air conditioner runs in "COOLING" or "DRY" mode with door or window opened for a long time when relative humidity is above 85%, dew may drip down from the air outlet.

Noise pollution

- Install the air conditioner at a place that can bear its weight in order to operate more quietly.

Features of protector

The protective device will work at following cases:

- Stopping the appliance and restarting it at once or changing mode during operation, you need to wait 3 minutes.

Inspection

After using for a long time , the air conditioner should be inspected on the following items:

- Overheat of the power supply cord and plug or even a burned smell.
 - Abnormal operating sound or vibration.
 - Water leakage from indoor unit.
 - Metal cabinet electrified .
- Stop the air conditioner if above trouble occurs.
It is advisable to have a detail inspection after using it for 5 years even if none of the above occurs.

Features of HEATING mode

Preheat

At the beginning of HEATING operation, the airflow from indoor unit is discharged 2-5 minutes later.

Defrost

In HEATING operation the appliance will defrost (de-ice) automatically to raise efficiency. This procedure usually lasts 2-10 minutes. During defrosting, fans stop operation. After defrosting completes, it returns to "HEATING" mode automatically.

- It is hard to raise the room temperature when outdoor temperature is very low. Use the air conditioner together with other heating appliance in this case.

Indoor unit

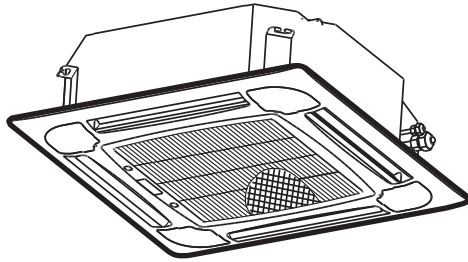

1.5/2.0Hp

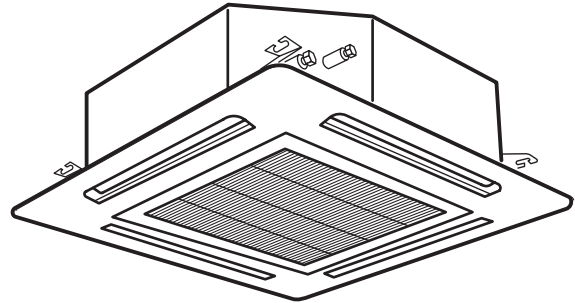

3.0~6.5Hp

outdoor unit

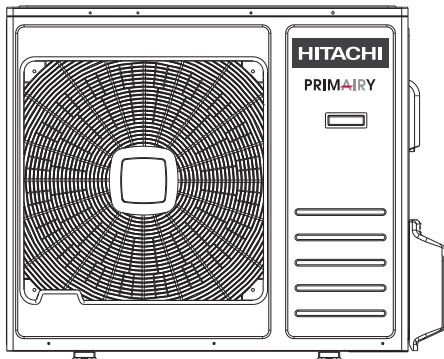

1.5~5.0Hp

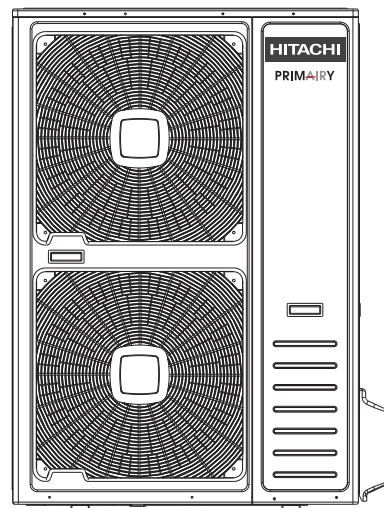

6.0/6.5Hp

*Note: This figure is based on the external view of a standard model.
Consequently, the shape may differ from that of the air conditioner you have selected.*

Wire remote controller(optional)

You can control the air-conditioner with the wire remote controller or wireless remote controller. It is used for controlling power ON/OFF, setting the running mode, temperature, fan speed and other functions. There are different types of remote controllers can be selected. Operate instruction will be further specified in remote controller's manual separately. Please read it carefully before using this appliance and keep it for future reference.

Wire remote controller



HCWA21NEWH

Wireless remote controller



HCRA31NEWH

Display Panel

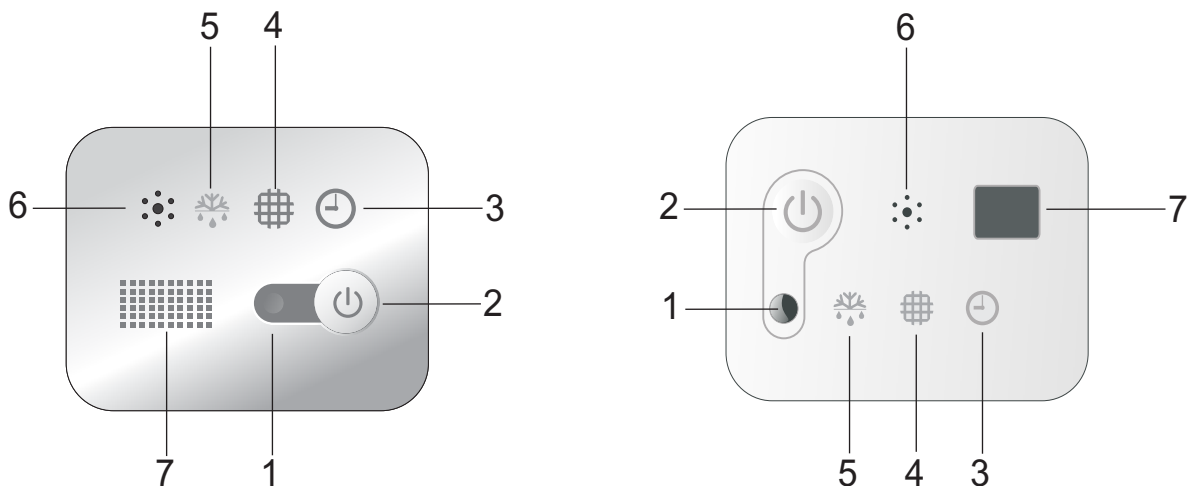

- 1 Run indicator (Red)
It lights on during operation. It lights off all when setting SLEEP mode.
- 2 Emergency switch
The filter clean is reset if press the switch. Press it the appliance will be stopped when the unit is running ; Press it for 5s,the appliance will be forced cooling when the unit is OFF.
- 3 Timer indicator (Green)
It lights on when timer is in use. It lights off when timer finishes.
- 4 *Filter clean (Yellow)
It lights on when the filter should be cleaned.
- 5 Defrost indicator (Green)
It lights on during the defrost. It lights off when defrost finishes.
- 6 Buzzer
It rings when the signal from remote controller is received.
- 7 Signal receiving section
Receives signal from the remote controller.

☑ • The figures in this manual are based on the external view of a standard model. Consequently, the shape may differ from that of the air conditioner you have selected.

* It can be set or canceled by professional after-sale staff.

Before Operation**⚠ CAUTION**

- Supply electrical power to system for approximately 12 hours before start-up after long shutdown.
- Do not start the system immediately after power supply, it may cause a compressor failure, because the compressor is not heated well.
- Make sure that the outdoor unit is not covered with snow or ice. If covered, remove it by using hot water (approximately 50°C). If the water temperature is higher than 50°C, it will cause damage to plastic parts.
- When the system is started after a shutdown longer than approximately 3 months, it is recommended that the system be checked by your service contractor.
- Turn OFF the main switch when the system is stopped for a long period of time. If the main switch is not turned OFF, electricity is consumed because the oil heater is always energized during compressor stopping.

1.Special remarks

- 3 minutes protection after compressor stop
To protect compressor, it will be continue off for at least 3 minutes once it has stopped.
- 5 minutes protection
Compressor must run 5 minutes at least once start running. In the 5 minutes, compressor will not stop even the room temperature reaches the set point unless you use remote control switch to turn off the unit(all indoor unit be turned off by user).
- Cooling operation
The fan of the indoor unit will never stop running. It remains running even if the compressor stops working.
- Heating operation
Since the air conditioner carries out the heating operation by drawing on the heat of the outside air (through heating pump), the heating capacity may decrease if the temperature outside the room is too low. If the heating effect is not so satisfying, use some other heating device together.
- Anti-freezing function during cooling
When the temperature of the air from the indoor outlet is too low, the unit will run for some time under the fan mode, to avoid frost or ice forming in the indoor heat exchanger.
- Cold air prevention
In several minutes after the heating mode is started, the fan of the indoor unit will not run until the heat exchanger of the indoor unit reaches a high enough temperature. That is because cold air prevention system is operating.
- Defrosting
When the outdoor temperature is too low, frost or ice may form in the outdoor heat exchanger, reducing heating performance. When this happens, a defrosting system of the air conditioner will operate. At the same time the fan in the indoor unit stops(or runs at a very low speed in some cases),a few minutes later, the defrosting is over, and the heating operation restarts.
- Blow out the survival heating air
When stop the air conditioner in normal operation, the fan motor would run with low speed for a while to blow out the survival heating air.
- Self Recovery of Power Break
When the power supply is recovered after break, all preset are still effective and the air-conditioner will run according to the previous setting before.

2. Setting of Automatic Swing Louver

Details please refer to Manual of Remote Controller.

⚠ CAUTION

Do not turn the air louver by hand, If moved, the louver mechanism will be damaged.

3.Filter Cleaning

⚠ CAUTION

Do not operate the system without air filter to protect the indoor unit heat exchanger against being clogged.

Turn OFF the main power switch before taking out the filter.(The previous operation mode may appear.)

3.1 Setting the Cleaning Period of Filter

Step 1

Enter choose and set mode.

It is time to clean the filter, when the light of "Filter" turn on.

Step 2

Cancel the setting

Press Emergency switch to return to the standard state.

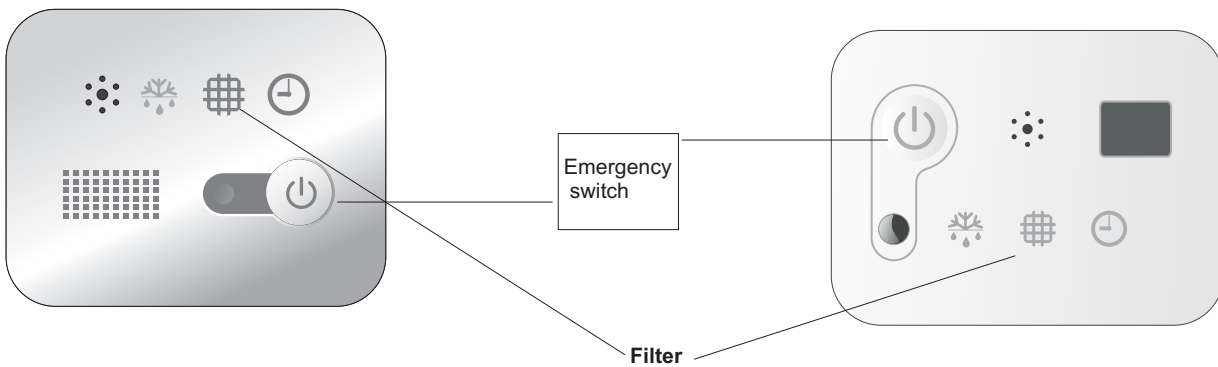

3.2 Take Out the Filter

Take out the air filter according the following steps.

Step1

Open the air inlet grille after pushing the two knobs as shown by the arrow mark.

Step2

Take out the air filter from the air inlet grille by supporting the air grille and lifting the air filter after detaching the filter from the hinges.

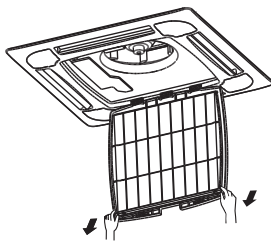
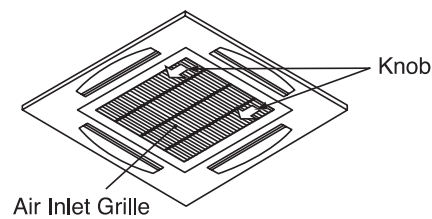
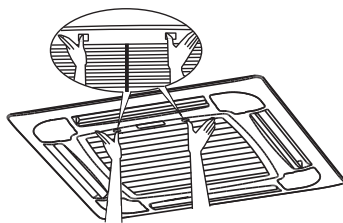

1.5~2.0Hp

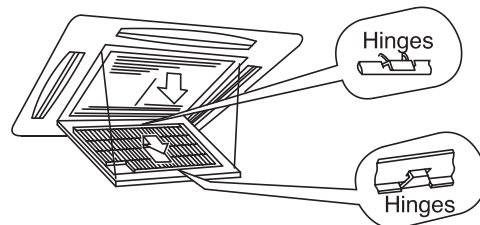

3.0~6.5Hp

3.3 Clean the Filter

Clean the air filter according to the following steps.

Step 1

Use a vacuum cleaner or let water flow onto the air filter for removing the dirt from the air filter.



Do not use hot water higher than approximately 40°C.

Step 2

Dry the air filter in the shade after shaking off moisture.

3.4 Reset of Filter indication

After cleaning the air filter, press the "Emergency switch" button. The FILTER indication will disappear and the next filter cleaning time will be set.

4. Trouble Shooting



When overflow of drain water from the indoor unit occurs, stop the operation and contact your contractor.

When you smell or see white smoke coming from the unit, turn OFF the main power supply and contact your contractor.

4.1 If Trouble Still Remains ...

If the trouble still remains even after checking the following, contact your contractor and inform them of the following items.

- (1) Unit Model Name
- (2) Content of Trouble

4.2 No Operation

Check whether the SET TEMP is set at the correct temperature.

4.3 Not Cooling or Heating Well

- Check for obstruction of air flow of outside or inside units.
- Check if too much heat source exists in the room.
- Check if the air filter is clogged with dust.
- Check to see if the doors or windows are opened or not.
- Check if the temperature condition is not within the operation range.

4.4 This is Not Abnormal

- **Smells from indoor unit**
Smell adheres on indoor unit after a long period of time. Clean the air filter and panels or allow a good ventilation.
- **Sound from Deforming Parts**
During system starting or stopping, an abrading sound might be heard. However, this is due to thermal deformation of plastic parts. It is not abnormal.
- **Steam from Outdoor Heat Exchanger**
During defrosting operation, ice on the outdoor heat exchanger is melted, resulting in making steam.
- **Dew on Air Panel**
When the cooling operation continues for a long period of time under high humidity conditions, dew can form on the air panel.
- **Refrigerant Flow Sound**
While the system is being started or stopped, sound from the refrigerant flow may be heard.

1.Refrigerant Flow Diagram

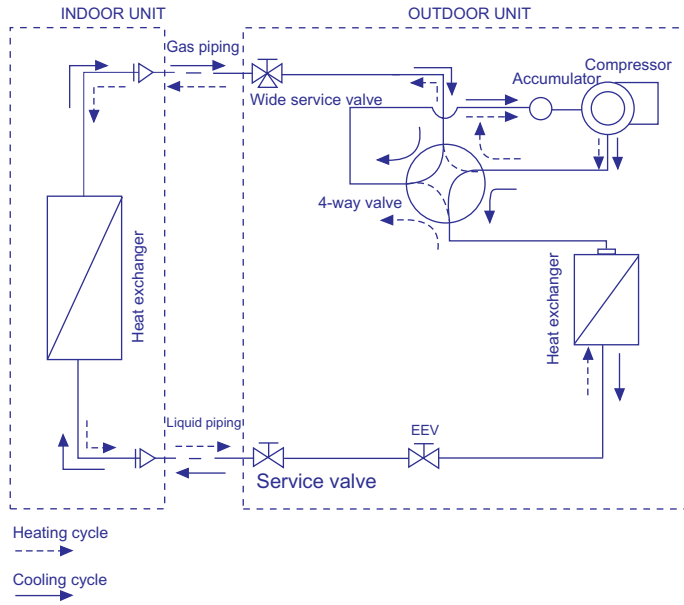

2.Electrical Wiring Diagram

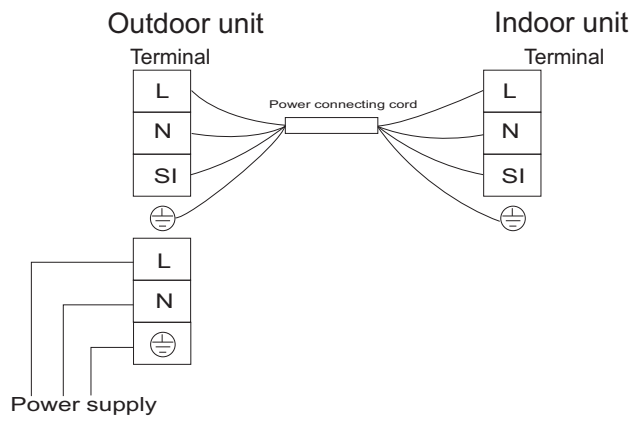

1.5~4.0Hp

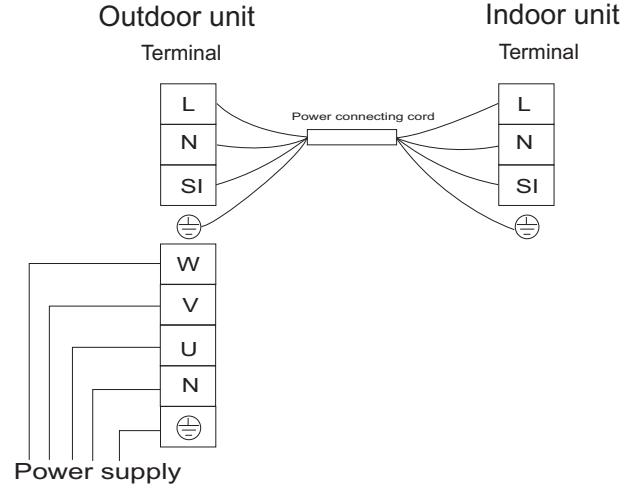

5.0~6.5Hp

1. Safety Notice

CAUTION

- Installation should be performed by dealer or another professional person. (Improper installation may cause water leakage, electrical shock, or fire.)
- Install the unit according to the instruction given in this manual. (Incomplete installation may cause water leakage, electrical shock, or fire.)
- Be sure to use the supplied or specified installation parts. (Use of other parts may cause the unit to come to lose, water leakage, electrical shock, or fire.)
- Install the air conditioner on a solid base that can support the unit weight. (An inadequate base or incomplete installation may cause injury in the event the unit falls off the base.)
- Electrical work should be carried out in accordance with the installation manual and the local national electrical wiring rules or code of practice. (Insufficient capacity or incomplete electrical work may cause electrical shock or fire.)
- Be sure to use a dedicated power circuit. (Never use a power supply shared by another appliance.)
- For wiring ,use a cable long enough to cover the entire distance with no connection, do not use an extension cord.
- Do not put other loads on the power supply , use a dedicated power circuit. (Failure to do so may cause abnormal heat, electric shock or fire.)
- Use the specified types of wires for electrical connections between the indoor and outdoor units. (Firmly clamp the interconnecting wires so their terminals receive no external stresses.)
- Incomplete connections or clamping may cause terminal overheating or fire.
- After connecting interconnecting and supply wiring be sure to shape the cables so that they do not put undue force on the electrical covers or panels. (Install covers over the wires, incomplete cover installation may cause terminal overheating, electrical shock or fire.)
- When installing or relocating the system, be sure to keep the refrigerant circuit free from substances other than the specified refrigerant (refer to nameplate) ,such as air. (Any presence of air or other foreign substance in the refrigerant circuit causes an abnormal pressure rise or rupture, resulting in injury.)
- If any refrigerant has leaked out during the installation work, ventilate the room. (The refrigerant produces a toxic gas if exposed to flames.)
- After all installation is completed, check to make sure that no refrigerant is leaking out. (The refrigerant produces a toxic gas if exposed to flames.)
- When carrying out piping connection, take care not to let air substances other than the specified refrigerant go into refrigeration cycle. (Otherwise, it will cause lower capacity, abnormal high pressure in the refrigeration cycle, explosion and injury.)
- Be sure to establish an earth. do not earth the unit to a utility pipe, arrester, or telephone earth. Incomplete earth may cause electrical shock. (A high surge current from lightning or other sources may cause damage to the air conditioner.)
- An earth leakage circuit breaker may be required depending on site condition to prevent electrical shock. (Failure to do so may cause electrical shock.)
- Disconnect the power supply before completion of wiring, piping , or checking the unit.
- When moving the indoor unit and outdoor unit , please be careful,do not make the outdoor unit incline over 45 degree. Pay attention to the sharp edge of the air conditioner to avoid any injury.
- Install the remote controller: Be sure that the length of the wire between the indoor unit and remote controller is within 40 meters.

CAUTION

- Do not install the air conditioner in a place where there is danger of exposure to inflammable gas leakage. (If the gas leaks and builds up around the unit, it may catch fire.)
- Establish drain piping according to the instructions of this manual. (Inadequate piping may cause flooding.)
- Tighten the flare nut according to the specified method such as with a torque wrench. (If the flare nut is tightened too hard, the flare nut may crack after a long time and cause refrigerant leakage.)

2. The Tools and Instruments for Installation

Number	Tool	Number	Tool
1	Standard screwdriver	8	Knife or wire stripper
2	Vacuum pump	9	Gradienter
3	Charge hose	10	Hammer
4	Pipe bender	11	Churn drill
5	Adjustable wrench	12	Tube expander
6	Tube cutter	13	Inner hexagon spanner
7	Cross head screw-driver	14	Tape measure

3. The Installation of the Indoor Unit



Do not install the indoor unit in a flammable environment to avoid fire or an explosion.



- Check to ensure that the ceiling slab is strong enough. If not strong enough the indoor units may fall down on you.
- Do not install the indoor unit outdoors. If installed outdoors, an electric hazard or electric leakage will occur.

3.1 The Initial Check

- Install the indoor unit with a proper clearance around it for operation and maintenance working space, as shown in Fig. 3.1.
- Provide a service access door near the unit piping connection area on the ceiling.
- Check to ensure that the ceiling has a sufficient strength to hang the indoor unit.
- Check the ceiling surface is flat for the air panel installation work.

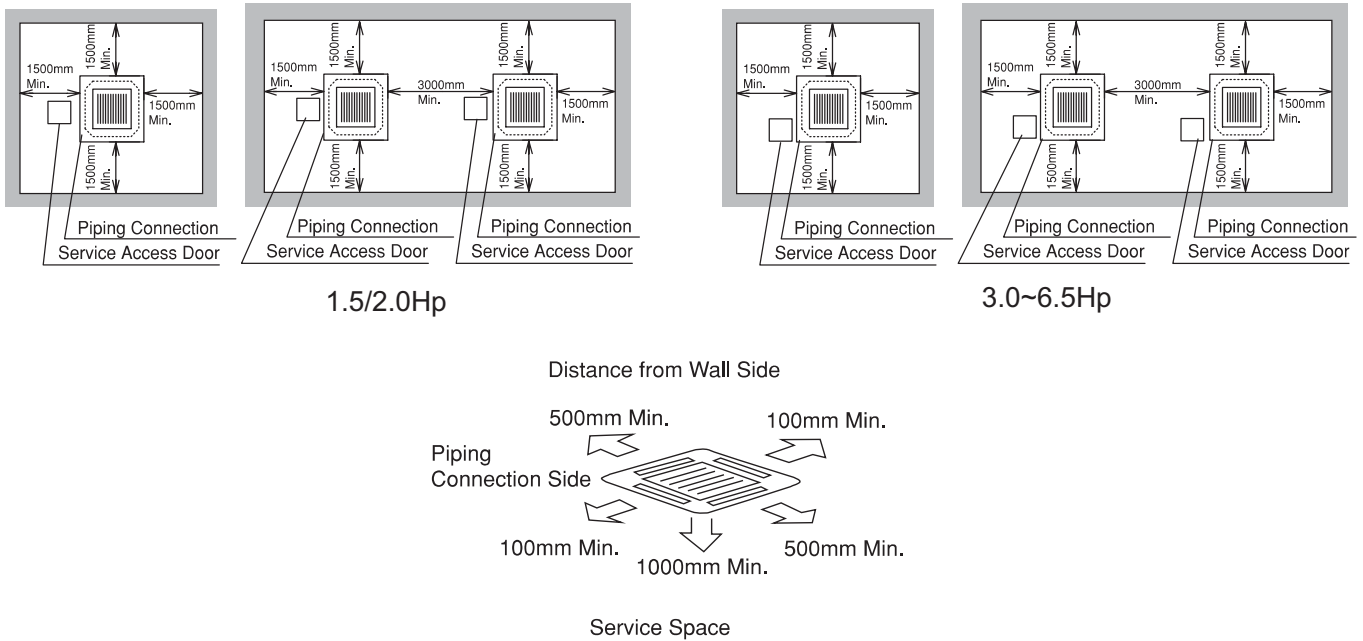
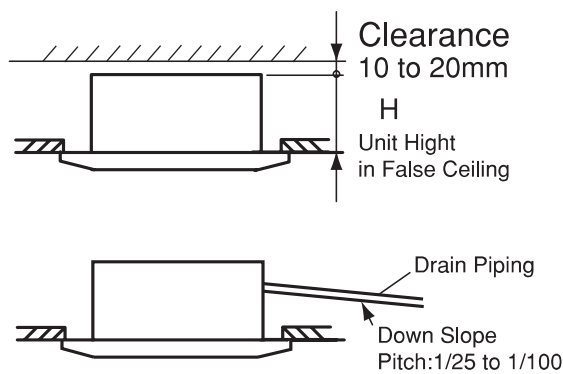

Fig. 3.1 Space around Indoor Unit

- Select the installation location as follows Fig 3.2 :
 - (A) Minimum Space
 - (B) Down Slope Pitch of Drain Piping: 1/25~1/100



(unit : mm)

Model Capacity (Hp)	H
1.5/2.0	270
3.0/4.0	248
5.0/6.0/6.5	298

Fig. 3.2 Installation Location of Indoor Unit

- Consider the air distribution from the indoor unit to the space of the room, and select a suitable location so that uniform air temperature in the room can be obtained. It is recommended that the indoor unit be installed 2.5 to 3 meters from the floor level.
- Do not install flammable parts in the service space for the indoor unit.
- Avoid obstacles which may hamper the air intake or the air discharge flow.

Installation and Maintenance

- Do not install the indoor unit in a machinery shop or kitchen where vapor from oil or its mist flows to the indoor unit. The oil will deposit on the heat exchanger, thereby reducing the indoor unit performance, and may deform and in the worst case, break the plastic parts of the indoor unit.
- Pay attention to the following points when the indoor unit is installed in a hospital or other facilities where there are electronic waves from medical equipment, etc.
 - (A) Do not install the indoor unit where the electromagnetic wave is directly radiated to the electrical box, remote control cable or remote control switch.
 - (B) Install the indoor unit and components as far as practical or at least 3 meters from the electromagnetic wave radiator.
 - (C) Prepare a steel box and install the remote control switch in it. Prepare a steel conduit tube and wire the remote control cable in it. Then, connect the ground wire with the box and the tube.
 - (D) Install a noise filter when the power supply emits harmful noises.
- To avoid any corrosive action to the heat exchanger, do not install the indoor unit in an acid or alkaline environment. In an application where the indoor unit is to be utilized under such environmental conditions, it is recommended that the corrosion-proof type unit be used.

WARNING

Check to ensure that the number of below is within 0.3kg/m³. Otherwise it may cause danger situation if the refrigerant in the Outdoor Unit leaks into the room where this Indoor Unit is installed.

$$\frac{\text{(Total Refrigerant Quantity per one Outdoor Unit)}}{\text{(Volume of the room where this Indoor Unit is installed.)}} \leq 0.3\text{kg/m}^3$$

3.2 Installation (1.5~2.0Hp)

3.2.1 Location for installing indoor unit

- Where there is no obstacle near the air outlet and air can be easily blown to every corner.
- Where drain pipe can extend outside of the wall from the ceiling board.
It is preferable to have a special draining facility.
- Where the roof is strong enough to bear the weight of indoor unit, and in not tend to increasing operation sound and vibration.
- Do not put anything near the air inlet grill to obstruct it from air absorption.
- Keep the unit and remote controller 1m or more apart from television, radio etc.
- To prevent the effects of a fluorescent lamps, keep the main unit from it at least 1.5m.
- Avoid installing at a place of greasy dirt or steam.

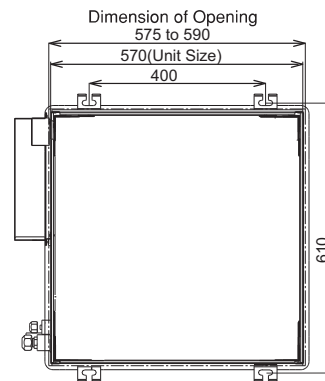
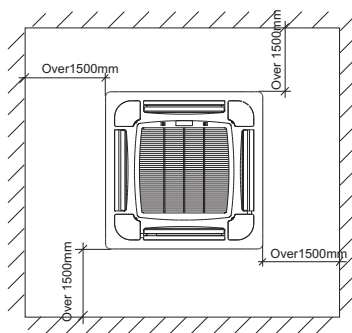
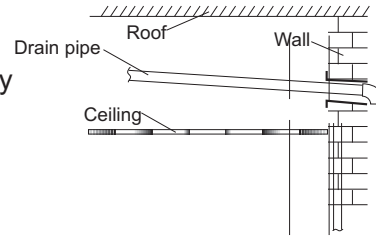

3.2.2 Height of ceiling board

Normally, keep it ceiling board 2.5m-3m above the ground.

3.2.3 Indoor unit installation

Pattern board for installation is printed on the packing. Cut off the pattern for opening the false ceiling and installation suspension bolts. (Note: Below reference is only applicable to a house made of concrete.)

- Measure the distance H between the roof surface and the ceiling board ;
- Make four suspending poles with M10 screw thread on both ends (metric system) as the below figure shown.(processed with $\Phi 10$ pole)

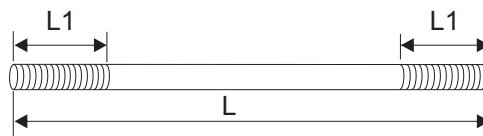
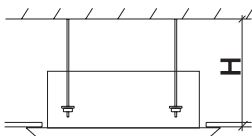

Value of L and L1 are calculated as below:

$$L1=50\text{mm (when } H<255\text{mm, } L1=40\text{mm)}$$

$$L=1.5L1+H-230 \text{ (unit: mm)}$$

- Turn 4 attached nuts onto the thread ends on the suspending poles as shown below:



Installation and Maintenance

- Take out the moulding board from the packing carton of indoor unit, do not fold it, just use it to decide an installation location and direction of the unit on the roof and ceiling. Press the moulding board tightly onto the surface of the roof, draw out the hole position for expand bolt with a pencil, then take off the moulding board, drill 8 holes for the expand bolts. It is preferable if the depth of holes just reveal the thread of the poles.
- Cut an opening (AxB) on the ceiling board with assistance of the pattern board, make sure to follow the same direction of the holes for roof bolts. Fix the edges of the opening with the “U”-shaped aluminum bars.

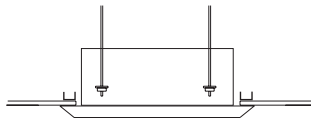

Model	A(mm)	B(mm)
1.5/2.0Hp	575~590	575~590

- Mount the attached suspending brackets with expand bolts M8X50 on the roof surface. Make sure to tighten the expand bolts and nuts well. The opening of suspending brackets should face outward as shown below.

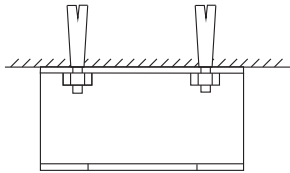

- Take out the suspending poles with nut on one end, mount them on the fixed suspending bracket, then tighten the nuts and washers on the top of the suspending brackets.

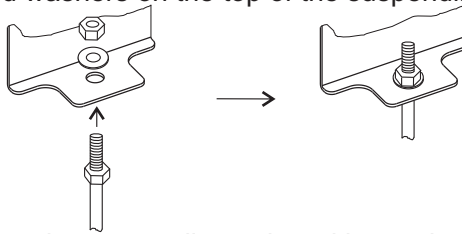

- Fix the main unit onto the suspending poles with attached nuts and washer. The nuts on the bottom should turn to about half of the thread length. (Note: This procedure needs at least 2 persons together.)

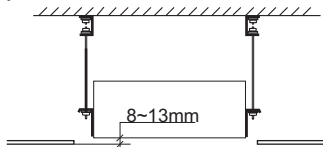

- Adjust the nuts on the bottom of the suspending poles, allow the bottom of the unit 8-13mm higher than that of the ceiling board. (as the above figure shown) Then adjust each corner of the bottom horizontally with a leveling ruler. (Levelness should be within the scope of 1/100.)

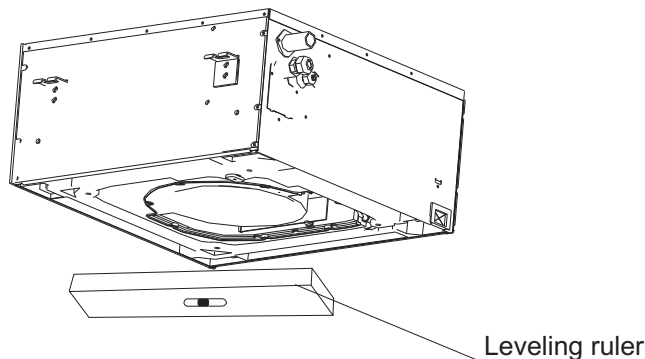

3.3 Installation (3.0~7.0Hp)

3.3.1 Opening of False Ceiling and Suspension Bolts

- (1) Determine the final location and installation direction of the indoor unit paying careful attention to the space for the piping, wiring and maintenance. Pattern board for installation is printed on the packing. Cut off the pattern for opening the false ceiling and installation suspension bolts.
- (2) Cut out the area for the indoor unit in the false ceiling and install suspension bolts, as shown in Fig. 3.3.

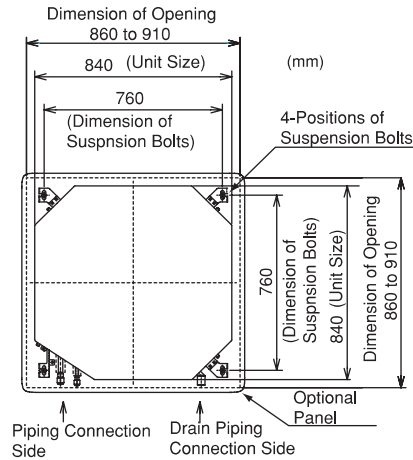

Fig. 3.3 Opening of False Ceiling and Suspension Bolts

- (3) Check to ensure that the ceiling is horizontally level, otherwise drainage can not flow.
- (4) Strengthen the opening parts of the false ceiling.
- (5) Mount suspension bolts, as shown in Fig. 3.4.

- For Concrete Slab

- For Steel Beam

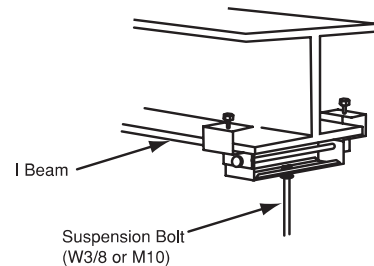
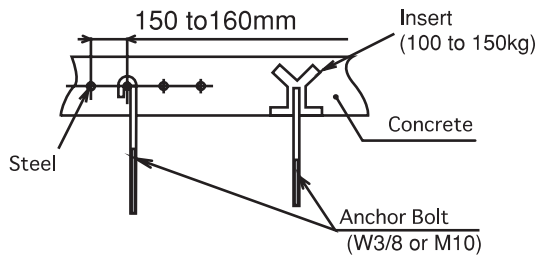
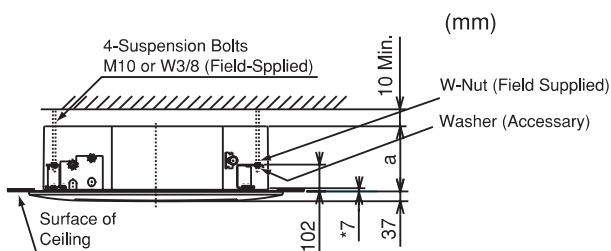

Fig. 3.4 Mounting Suspension Bolts

3.3.2 Mounting Position of the Indoor Unit



* indicates the dimension between lower face of indoor unit and surface of ceiling.

Model	a
3.0/4.0	248
5.0/6.0/6.5	298

Fig. 3.5 Mounting Position

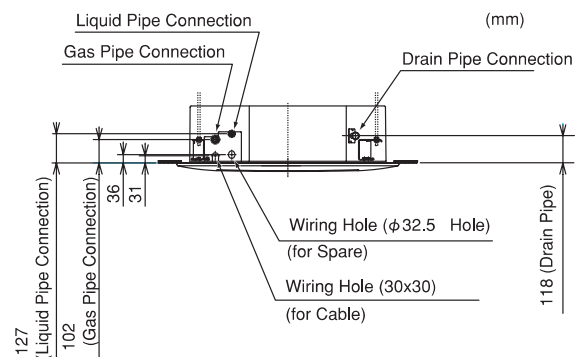

Fig. 3.6 Indoor Unit and Air Panel

3.3.3 Mounting the Indoor Unit

(1) Mount the nuts and washers to the suspension bolts.

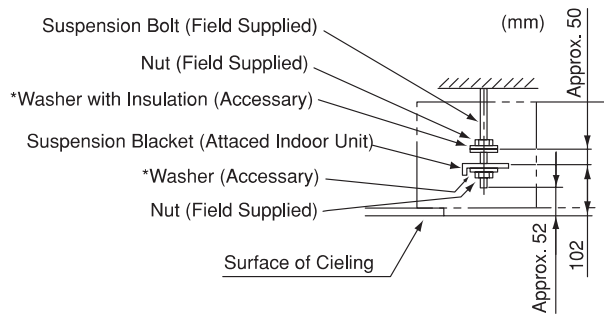

Fig. 3.7 Mounting Nuts and washer

*Put the washer so that the surface with insulation can faces downwards.

- (2) Lift the Indoor Unit by hoist, and do not put any force on the drain pan.
 (3) Secure the indoor unit using the nuts, washer.

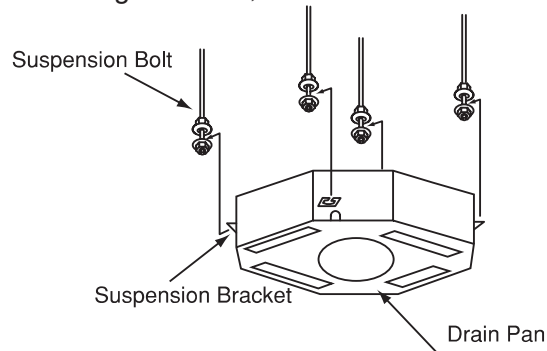

Fig. 3.8 Mounting the Indoor Unit

NOTE: If a false ceiling has already been installed, complete all piping and wiring work inside the ceiling before hooking-up the indoor unit.

3.3.4 Adjusting the Space between Indoor Unit and False Ceiling Opening



- Check the level of the drain pan using a water level to avoid incorrect operation of the drain discharge mechanism in the indoor unit. The drain piping side of the indoor unit must be approximately 5mm lower than the other part.
- Tighten the nuts of the suspension brackets after the adjustment is completed. Apply LOCK-TIGHT paint* to the bolts and nuts in order to prevent them from loosening. If not done, abnormal noises or sounds may occur and the indoor unit may fall down.

LOCK-TIGHT paint*: Paint the lock bolts and nuts. Adjust the indoor unit to the correct position while checking with the checking scales (factory-supplied).

- (1) Pattern Board for installation is attached with the packing.
- (2) Adjust the position of indoor unit, as shown below by using checking scale .

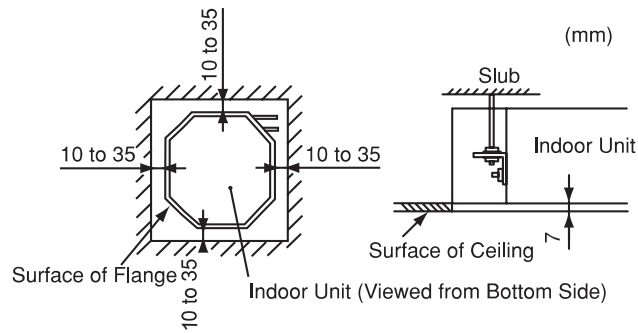

a .For Ceiling already Completed with Panels

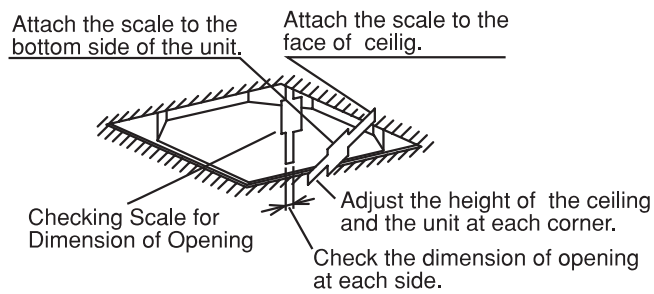

b . Ceiling not Completed with Panels yet

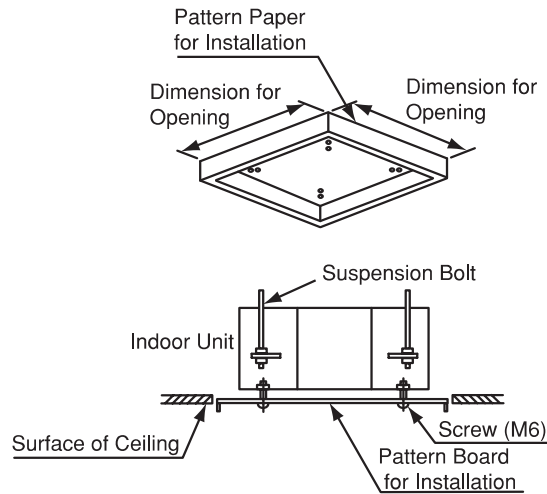

3.4 Installation Details for Air Panels

- The details of installation work for air panel shall be according to the Installation Manual for Air Panel.
- Check to ensure that the connection of connector between the indoor unit and the air panel.

4. The Installation of Outdoor Unit

4.1 The Initial Check

- The outdoor should be kept in well ventilated and dry place.
- Make sure that the noise and exhaust do not disturb your neighbors .
- Never install the outdoor unit at the place with high oil fog, acidic, alkaline, salt mist or harmful gas such as sulfur steam.
- Far away from radiation source at least 3 meters.
- Install snow hood before the inlet and outlet of the outdoor unit , when the machine is installed at the ice area.
- Install the machine in shade place to avoid the sunshine directly and the high temperature heat radiation.
- Not install the machine at the place with dustiness or pollution avoid the heat exchanger blocked.
- Not install the machine at the place easy to touch.
- Not install the machine at the place where the monsoon or the wind between building can blow the fan directly.

NOTE: The fan could be destroyed by the strong wind when it blow the exchanger part of the outdoor unit directly .

Be careful of the Aluminum foil fin, it is sharp.

There is no one allowed to touch the outdoor unit except the service engineer.

4.2 Installation

- (1) Use the washer provided in the accessory to fasten the machine at the foundation bolts.
 - (2) When fasten the outdoor unit with the foundation bolts, the fasten holes position as the Fig4.2.
 - (3) Fasten the outdoor unit as the Fig4.3.
 - (4) Make sure fasten the outdoor unit tight and horizontal avoid to make noise when the machine oblique Or inclined by strong breeze or earthquake.
 - (5) Not drain off water to the public places avoid to slip.
 - (6) Make a strong base(made of concrete or alike). The appliance should be placed not less than 10 cm high to avoid being wet or corroded. Otherwise, it may cause damage to the appliance or reduce its life time. (Figure 4.4)
- Fix the unit with wire ropes to prevent overturning in case a seasonal strong wind (storm, etc.) blows against the unit (Figure 4.5).

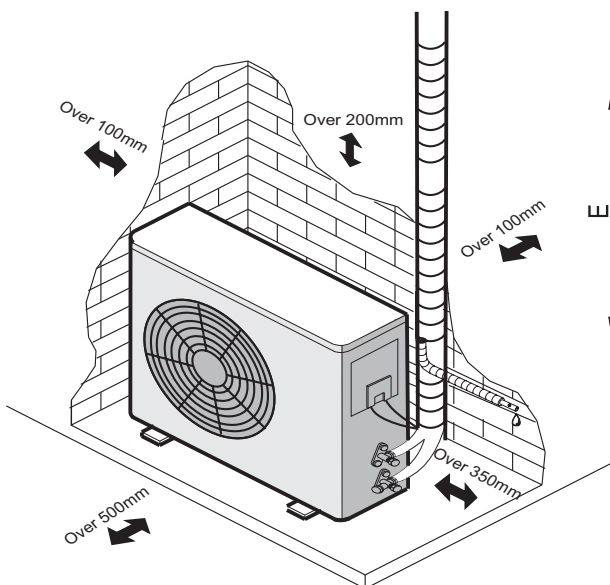
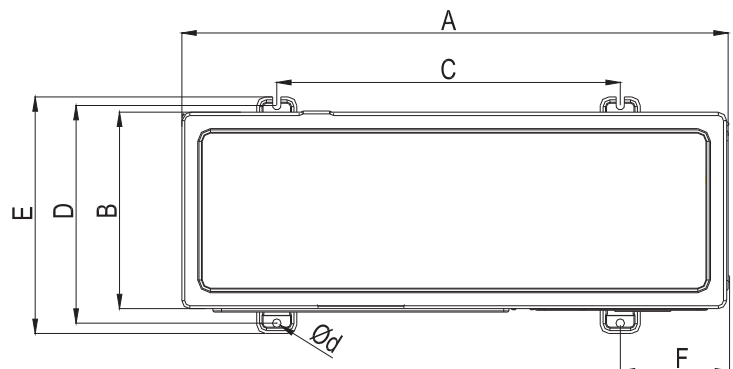

Fig.4.1



DC-Inverter Unitary Air Conditioner

(Unit:mm)

Model Capacity(Hp)	A	B	C	D	E	F	d
1.5	810	281	510	310	338	150	10×17
2.0/3.0	860	310	542	341	368	168	11×17
4.0/5.0/6.0/6.5	950	340	580	378	410	185	15

Fig.4.2 The position of anchor bolts

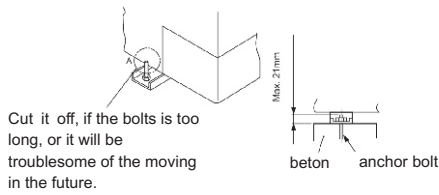

Fig. 4. 4 The installation of anchor bolts

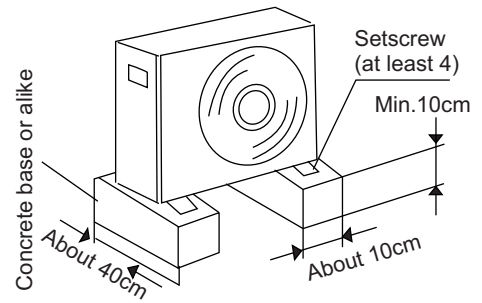

Fig.4.5

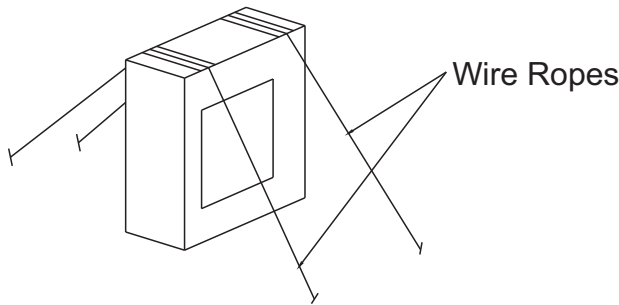

Fig.4.6

4.3 Refrigerant Length between Indoor and Outdoor

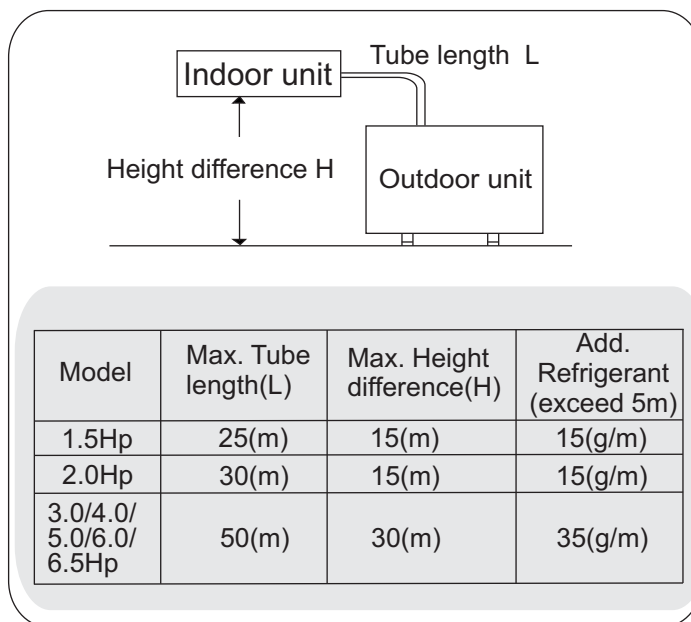

Fig.4.7

If the total tube length is between 5m to 50m (Max. length), an additional refrigerant can be added. It's not necessary to add compressor oil. (Figure 4.7) Pay attention to the Max. tube length and Max. height difference allowed when perform this work.

5. Refrigerant Piping

⚠ DANGER

Use refrigerant R410A in the refrigerant cycle(refer to outdoor nameplate). Do not charge oxygen, acetylene or other flammable and poisonous gases into the refrigerant cycle when performing a leakage test or an air-tight test. These types of gases are extremely dangerous and can cause an explosion. It is recommended that compressed air, nitrogen or refrigerant be used for these types of tests.

5.1 The Piping Materials

- (1) Prepare locally-supplied copper pipes.
- (2) Select the piping size from the following table.

	Gas pipe (mm)	Liquid pipe (mm)
1.5	ø9.52	ø6.35
2.0	ø12.7	ø6.35
3.0	ø15.88	ø9.52
4.0/5.0/6.0/6.5	ø19.05	ø9.52

- (3) Select clean copper pipes. Make sure there is no dust and moisture inside. Blow the inside of the pipes with nitrogen or dry air, to remove any dust or foreign materials before connecting pipes.

5.2 The Piping Connection

- (1) Position of piping connection is shown in Fig. 5. 1. (Indoor Unit)

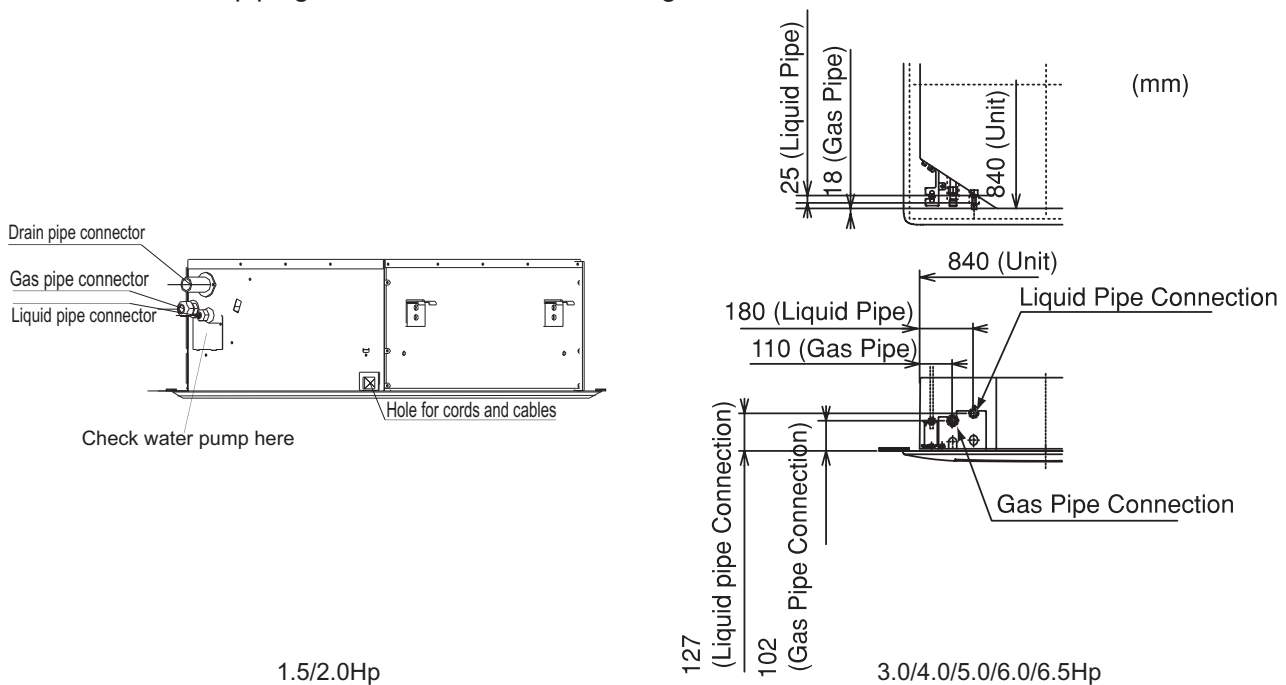
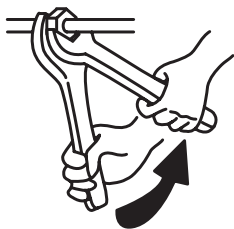

Fig. 5.1 Position of Piping Connection

- (2) When tightening the flare nut, use two spanners as shown in Fig. 5. 2.



Pipe Size(mm)	Tightening Torque (N.m)
φ 6.35	20
φ 9.52	40
φ 12.7	60
φ 15.88	80
φ 19.05	100

Fig. 5.2 Tightening Work of Flare Nut

- (3) After connecting the refrigerant piping, seal the refrigerant pipes by using the factory-supplied insulation material as shown in Fig5. 3.

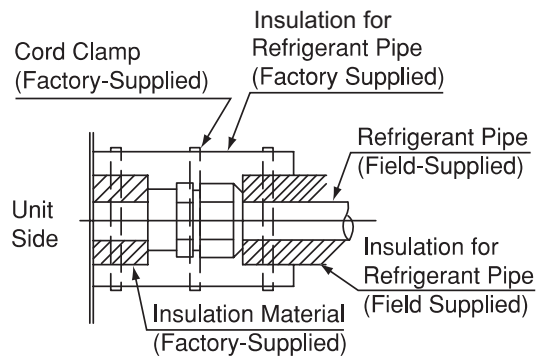

Fig. 5.3 Insulation on Pipes

⚠ CAUTION

- Cap the end of the pipe when the pipe is to be inserted through a hole.
- Do not put pipes on the ground directly without a cap or vinyl tape at the end of the pipe.

5.3 Air Exhaust

Air and moisture remaining in the refrigerant system have undesirable effects.

Therefore, they must be purged completely following the steps.

Air Purging with a Vacuum Pump

- (1) Check that each tube (both narrow and wide tubes between the indoor and outdoor units) have been properly connected. Note that both narrow and wide tube valves on the outdoor unit are kept closed at this stage.
- (2) Using an adjustable wrench or box wrench, remove the bonnet from the service valve.
- (3) Connect a vacuum pump and service valve together tightly.
- (4) Turn on the vacuum pump and till the pressure is lower than -755mm Hg for 5 minutes.
- (5) With the vacuum pump still running, demount tube of vacuum pump from the service valve. Then stop the vacuum pump.
- (6) Replace the bonnet on the service valve and fasten it securely with an adjustable wrench or box wrench.
- (7) Using an adjustable wrench or box wrench, remove the bonnet of both narrow and wide valve.
- (8) With the hex wrench, turn the wide and narrow tube valves stem counter clockwise to fully open the valves.
- (9) Replace the bonnets on the wide and narrow valves and fasten it securely with an adjustable wrench or box wrench.

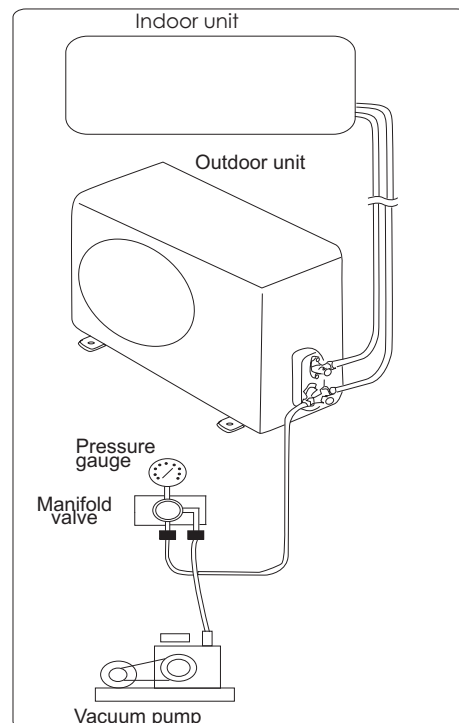
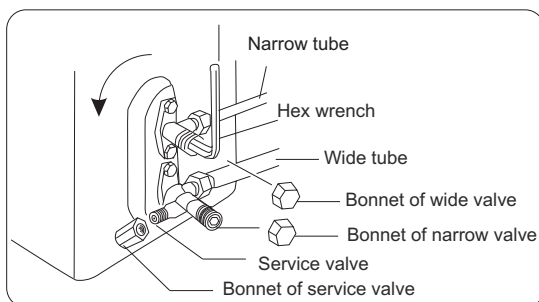

Fig. 5.4 Air Purging

6. Drain Piping

CAUTION

- Do not create an upper-slope or rise for the drain piping, since drain water can flow back to the indoor unit and leakage into the room will occur when the system operation is stopped.
- Do not connect the drain pipe with sanitary or sewage piping or any other drainage piping.
- When the common drain piping is connected with other indoor units, the connected position of each indoor unit must be higher than the common drain pipe must be large enough according to the unit size and number of units.
- After performing drain piping work and electrical wiring, check to ensure that water flows smoothly as in the following procedure.
- Checking with the Float Switch:
 - (A) Switch ON the power supply.
 - (B) Pour 1.8 liters of water into the drain pan.
 - (C) Check to ensure that the water flows smoothly or whether no water leakage occurs.
When water cannot be found at the end of the drain piping, pour another 1.8 liters of water into the drain.
 - (D) Switch ON the power supply and press the RUN/STOP button.

- In case of pouring water through the access door.

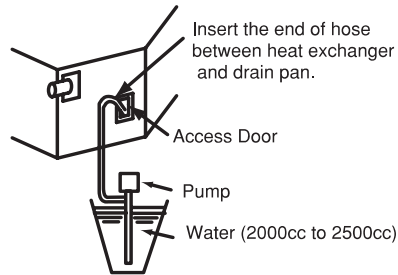

- In case of pouring water through the air outlet.

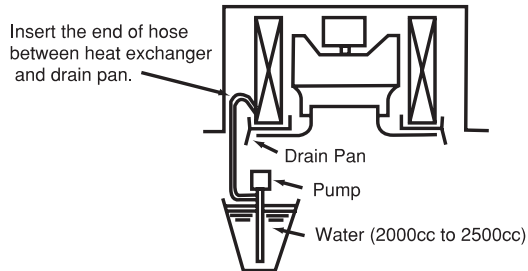

Installation and Maintenance

- Prepare a polyvinyl chloride pipe with a 21mm inside diameter(1.5/2.0).
Prepare a polyvinyl chloride pipe with a 32mm outer diameter(3.0~7.0).
- Fasten the tubing to drain hose with the adhesive agent and factory-supplied clamp . The drain piping must be performed with a down-slope pitch of 1/25 to 1/100.

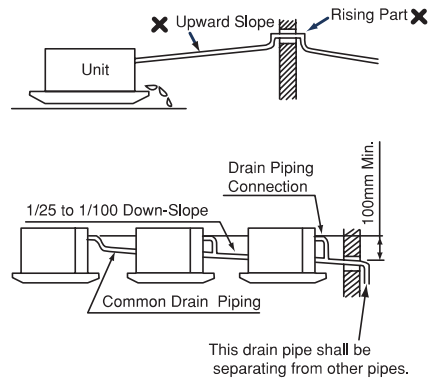
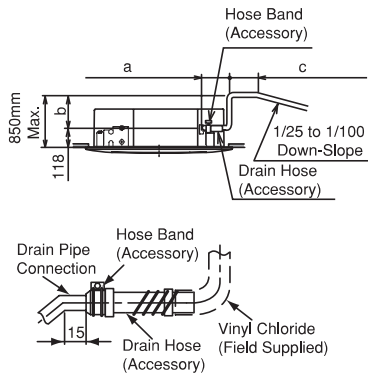

*The total length of a+b+c :

For Model 1.5/2.0 : $a \leq 300$, $b \leq 500$, $c \leq 50$

For Model 3.0~6.5: $a \leq 300$, $b \leq 850$, $c \leq 50$, $a+b+c \leq 1100$

*In case of lifting the drain pipe at outlet part, perform the drain piping work as shown in the above figure.

- Insulate the drain pipe after connecting the drain hose.

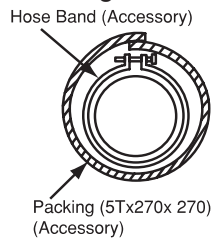

7. Electrical Wiring

WARNING

- Turn OFF the main power switch to the indoor unit and the outdoor unit before electrical wiring work or a periodical check is performed.
- Check to ensure that the indoor fan and the outdoor fan have stopped before electrical wiring work or a periodical check is performed.
- Protect the wires, drain pipe, electrical parts, etc. from rats or other small animals. If not protected, rats may gnaw at unprotected parts and at the worst, a fire will occur.
- Check the item below before turning ON the main switch.
- Tighten screws according to the following torque
 - M3.5: 1.2N-m
 - M5: 2.0~2.4 N-m

CAUTION

- Wrap the accessory packing around the wires, and plug the wiring connection hole with the seal material to protect the product from any condensate water or insects.
- Tightly secure the wires with the cord clamp inside the indoor unit.
- Secure the cable of the remote control switch using the cord clamp inside the electrical box.

7.1 General Check

- (1) Make sure that the field-selected electrical components (main power switches, circuit breakers, wires, conduit connectors and wire terminals) have been properly selected according to the electrical data given in "9.Common". Make sure that the components comply with National Electrical Code (NEC).
- (2) Check to ensure that the power supply voltage is within $\pm 10\%$ of the rated voltage.
- (3) Check the capacity of the electrical wires. If the power source capacity is too low, the system cannot be started due to the voltage drop.
- (4) Check to ensure that the ground wire is connected.
- (5) Power Source Main Switch Install a multi-pole main switch with a space of 3.5mm or more between each phase.

7.2 Electrical Wiring Connection

The intermediate connection between the indoor unit and the air panel should be referred to in the "Installation Manual for Air Panel".

- (1) Connect the power supply and earth wires to the terminals in the electrical box.
- (2) Connect the wires between the indoor unit and the outdoor unit to the terminals in the electrical box.

8. Test Run

WARNING

- Only after all the checking points have been checked the unit can be operated.
 - (A) Check and make sure that the resistance of the terminal to ground is more than 2 MΩ, otherwise, you cannot operate the unit before the electricity leakage point is found and repaired.
 - (B) Check and make sure that the stop valve has been opened before operating the unit.
 - (C) Make sure that turn on electric power 6 hours before operating the unit.
 - Make sure the power and unit run well then plug in.
 - Turn on the appliance and adjust it to Cooling or Heating mode according to the room temperature. Set at lowest temperature when cooling mode and highest temperature when heating mode. Check if the appliance can run well.
 - Installation of the appliance is generally finished after the above operations are done. If you still have any trouble, please contact local technical service center of our company for further information.
 - ***Pay attention to the following items while the system is running.***
 - (A) Do not touch any of the parts by hand at the discharge gas side, since the compressor chamber and the pipes at the discharge side are heated higher than 90°C.
 - (B) Use remote controller to operate, and check whether room temperature and function well.
- After test, turn off the electric power.

9. Common



- Use an ELB (Electric Leakage Breaker). If not used, it will cause an electric shock or a fire.
- Do not operate the system until all the check points have been cleared.
 - (A) Check to ensure that the insulation resistance is more than 2 MΩ, by measuring the resistance between ground and the terminal of the electrical parts. If not, do not operate the system until the electrical leakage is found and repaired.
 - (B) Check to ensure that the stop valves of the outdoor unit are fully opened and then start the system.

Model Capacity(Hp)	Power Supply	ELB		Power Source Cable Size	Transmitting Cable Size
		Nominal Current(A)	Nominal Sensitive Current (mA)	En60335-1	En60335-1
1.5	220-240V ~,50Hz	20	30	3×1.5mm ²	4×1.5mm ²
2.0	220-240V ~,50Hz	20	30	3×2.5mm ²	4×1.5mm ²
3.0	220-240V ~,50Hz	32	30	3×2.5mm ²	4×1.5mm ²
4.0	220-240V ~,50Hz	40	30	3×4.0mm ²	4×1.5mm ²
5.0/6.0/6.5	380-415V 3N~,50Hz	32	30	5×2.5mm ²	4×1.5mm ²

Max. Running Current(A):REFER TO NAMEPLATE

NOTES:

- 1) Follow local codes and regulations when selecting field wires, and all the above are the minimum size.
- 2) The wire sizes marked in the table are selected at the maximum current of the unit according to the European Standard, EN60335-1. Use the wires which are not lighter than the ordinary polychloroprene sheathed flexible cord (code designation H07RN-F).

When connecting the terminal block using flexible cord, make sure to use the round crimp-style terminal for connection to the power supply terminal block.

Place the round crimp-style terminals on the wires up to the covered part and secure in place.

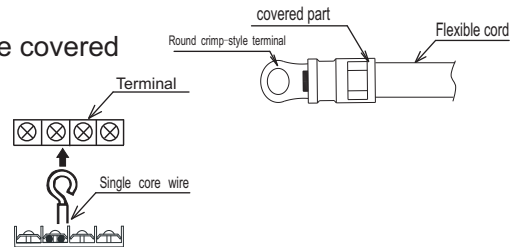

When connecting the terminal block using a single core wire, be sure to perform curing.

- 3) When transmitting cable length is more than 15 meters, a larger wire size should be selected.
- 4) Use a shielded cable for the transmitting circuit and connect it to ground.
- 5) In the case that power cables are connected in series, add each unit maximum current and select wires below.

Selection According to EN60335-1

Current i(A)	Wire Size(mm ²)
$i \leq 6$	0.75
$6 < i \leq 10$	1
$10 < i \leq 16$	1.5
$16 < i \leq 25$	2.5
$25 < i \leq 32$	4
$32 < i \leq 40$	6
$40 < i \leq 63$	10
$63 < i$	*

*In the case that current exceeds 63A, do not connect cables in series.



Correct Disposal of this product

This marking indicates that this product should not be disposed with other household wastes throughout the EU. To prevent possible harm to the environment or human health from uncontrolled waste disposal, recycle it responsibly to promote the sustainable reuse of material resources. To return your used device, please use the return and collection systems or contact the retailer where the product was purchased. They can take this product for environmental safe recycling.

Specifications in this document are subject to change without notice, in order that Hitachi-Johnson Controls Air Conditioning, Inc. may bring the latest innovations to their customers.

Hitachi-Johnson Controls Air Conditioning, Inc.